



KONICA MINOLTA

THERMAL IMAGER

DRYPRO TH



- ◆ Compact / lightweight and does not require a large installation space.
- ◆ Receives and prints certified image sources, such as medical diagnostic equipment (modalities) and workstations, via the DICOM network. It is possible to send print jobs from multiple image sources simultaneously.
- ◆ Output from CS-7 / ImagePilot and DICOM modalities.



Medical film TR-S			
8×10 inch (20.3×25.4cm)	10×12 inch (25.4×30.5cm)	14×17 inch (35×43cm)	B4 (26×36cm)
100 sheets			

RETHINK WHAT'S POSSIBLE

Giving Shape to Ideas

THERMAL IMAGER DRYPRO TH

Specifications

Printing method	Thermal head printing
Number of tray	1
Applicable film	Konica Minolta Medical Dry Imaging film TR-S
Film size	14×17 inch (35×43cm), B4 (26×36 cm), 10×12 inch (25.4×30.5 cm), 8×10 inch (20.3×25.4 cm)
Film packing unit	100 sheets
Preventing contamination with other companies' films	With RFID
Performance (max.)	14×17 inch : Approx. 50 sheets / hour
Initial Printing time	14×17 inch : Approx. 105 sec.
Printed pixel size	84.7 μm (300 dpi)
Printing bit depth (gradations)	12 bits (4094 levels)
Format	1, 2, 3, 4, 6, 8, 9, 12, 15, 16, 18, 20, 24, 25, 28, 30, 32, 35, 36, 40, 42, 48, 49, 54, 56, 60, 64, 70
External dimensions(W×D×H) mm	1 tray 530×470×365
Weight	1 tray approximately 32 kg
Ambient operating conditions	40% to 70% (at 15°C), 15% to 70% (at 30°C) (no condensation)
Power supply rating	AC 100-240V 5-2A 50-60Hz

Option

DP TH MAGAZINE L	L magazine (for compatible 14×17inch size)
DP TH MAGAZINE S	S magazine (for compatible B4, 10×12 inch, 8×10 inch size)



Dimensions

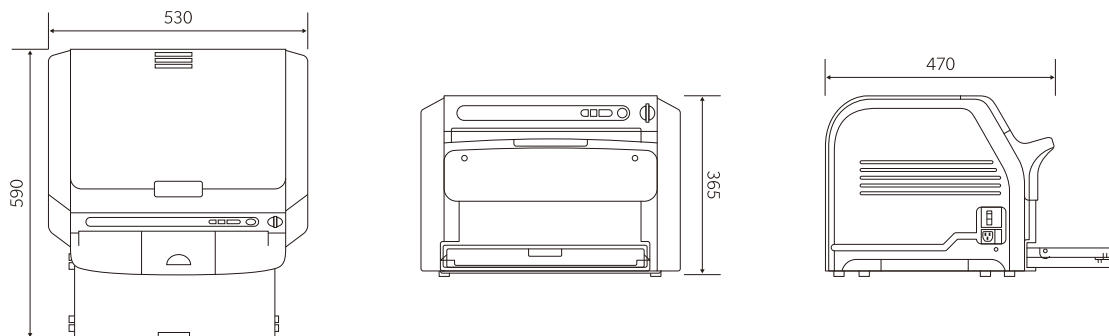

Unit : mm, 1/15 scale

★ Specifications are subject to change without pr or notice.

Marketed & Serviced by :

KONICA MINOLTA HEALTHCARE INDIA PVT. LTD.

Office No 1121, 2nd Floor, Building No 11, Solitaire Corporate Park, Chakala, Andheri East, Mumbai 400093.

Tel.: 91-22-61916900 | Email: sales@mi.konicaminolta.in

Website: www.konicaminolta.in/healthcare

CALL TOLL FREE FOR SUPPORT : 1800 - 121 - 2313

Monday to Saturday (9:00 AM to 07:00 PM)

Distributed by:

